

P E T R A I A





# UNA VISIONE

A VISION OF HOME • UNE VISION ORIGINALE DE LA MAISON

# DI CASA

EINE VISION VOM WOHNEN

Elementi capaci di cogliere e tradurre aspetti della personalità: un ambiente di vita come specchio di idee del proprio essere. Una visione di casa. Dove calore e ospitalità siano protagonisti di un'atmosfera piacevolmente vissuta, che affonda le sue radici nella tradizione di un classico reinterpretato.

Elements capable of perceiving and translating aspects of one's personality: a living ambient as the mirror of one's ideas. A vision of home. Where warmth and hospitality are the protagonists of a pleasant mood of yesteryear, that fills its nostrils with the tradition of a revamped classic.

Éléments en mesure de saisir et de traduire les différents aspects de la personnalité : un intérieur dont l'atmosphère reflète les idées de son propriétaire. Une vision originale de la maison dont le caractère chaleureux et hospitalier dégage une atmosphère vécue de façon agréable qui plonge ses racines dans la tradition d'un style classique réinterprété.

Elemente, die Aspekte der eigenen Persönlichkeit aufgreifen und umsetzen. Lebensraum als Spiegel des Seins. Eine Vision vom Wohnen. Wo Wärme und Gastlichkeit ein Ambiente prägen, das Schauplatz von Leben ist. Wo zeitgemäß umgesetzte Klassik tief in der Tradition verwurzelt ist.



# DIECI X 10

SPAZIO AL PICCOLO

**BORDI**  
EDGES

Bordi irregolari • Uneven edges • Bords irréguliers • Unregelmäßige Kanten



# COLORI

COLOURS

DIECI X 10  
SPAZIO AL PICCOLO



BIANCO



ALMOND



BEIGE



OCRA

Dettagli di stile, per ambienti che non rinunciano a essere preziosi. Un piccolo tocco di classe che non passerà inosservato. Sfumature naturali, atmosfere di casa e l'intimità dei particolari scandiscono i ritmi della vita quotidiana.

Style details, for ambients that do not relinquish preciousity. A fine touch of class that does not go unnoticed. Natural shading, homely moods and the intimacy of detail dictate the rhythm of daily life.

Détails de style pour un intérieur qui ne renonce pas à son caractère précieux. Une touche de classe tout en délicatesse qui ne passera pas inaperçue. Nuances naturelles, atmosphère intime et détails familiers rythment les moments de la vie quotidienne.

Stilvolle Details für ein Ambiente, das Erlesenheit atmet. Ein ausgesuchter Akzent von Exklusivität, der nicht unbemerkt bleibt. Natürliche Nuancen, Wohnatmosphäre und intimistische Reminiszenzen setzen dem Alltag ihre Note auf.



COTTO



ROSSO



VERDE



NERO



MONOCOTTURA DA RIVESTIMENTO • SINGLE-FIRED WALL TILES  
MONOCUISSON POUR REVÊTEMENT • EINBRAND-WANDFLIESEN



**-A2007.0**

Petraia cotto

10x10 / 3.9" x 3.9"  68



**-A2007.A**

Dec. soffio mix cotto

10x10  12



**-A2000.G**

Form. maiolica mix almond

10x10  12



**-A2007.C**

Dec. fiorito mix cotto

10x10  12



**-A2007.B**

List. soffio cotto

5x20  24



**-A2000.H**

List. maiolica almond

5x20  12



**-A2007.D**

List. fiorito mix cotto

5x10  12



COTTO



**-A2007.I**

Dec. uliveto mix cotto

10x10  12

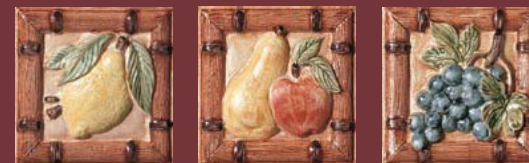

**-A2005.M**

Form. fructis mix ocra/cotto/rosso

10x10  12



**-A2005.N**

List. fructis ocra/cotto/rosso

3,5x20  12

PEZZI SPECIALI • SPECIAL TRIMS  
ÉLÉMENTS SPÉCIAUX • SPEZIALTEILE



**-A2007.17**

Double bullnose cotto

10x10  18



**-A2007.16**

Bullnose cotto

10x10  18



**-A2007.26**

Torello cotto

5x20  12



**-A2007.28**

Bombato cotto

2x20  12



**-A2007.27**

Ang. tor. cotto

5x3  12



**-A2007.29**

Ang. bombato cotto

2x2  12



PETRAIA BIANCO/OCRA  
DEC. ULIVETO MIX OCRA  
TAVELLA OCRA 12,5x25



MONOCOTTURA DA RIVESTIMENTO • SINGLE-FIRED WALL TILES  
MONOCUISSON POUR REVÊTEMENT • EINBRAND-WANDFLIESEN



**-A2005.0**

Petraia ocră

10x10 / 3.9" x 3.9"  68



**-A2005.A**

Dec. soffio mix ocră

10x10  12



**-A2000.G**

Form. maiolica mix almond

10x10  12



**-A2005.C**

Dec. fiorito mix ocră

10x10  12



**-A2005.B**

List. soffio ocră

5x20  24



**-A2000.H**

List. maiolica almond

5x20  12



**-A2005.D**

List. fiorito mix ocră

5x10  12



OCRA



**-A2005.I**

Dec. uliveto mix ocră

10x10  12

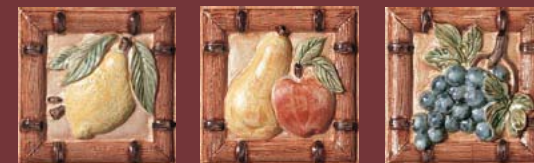

**-A2005.M**

Form. fructis mix ocră/cotto/rosso

10x10  12



**-A2005.N**

List. fructis ocră/cotto/rosso

3,5x20  12

PEZZI SPECIALI • SPECIAL TRIMS  
ÉLÉMENTS SPÉCIAUX • SPEZIALTEILE



**-A2005.17**

Double bullnose ocră

10x10  18



**-A2005.16**

Bullnose ocră

10x10  18



**-A2005.26**

Torello ocră

5x20  12



**-A2005.27**

Ang. tor. ocră

5x3  12



**-A2005.28**

Bombato ocră

2x20  12



**-A2005.29**

Ang. bombato ocră

2x2  12



MONOCOTTURA DA RIVESTIMENTO • SINGLE-FIRED WALL TILES  
MONOCUISSON POUR REVÊTEMENT • EINBRAND-WANDFLIESEN



**-A2004.0**

Petraia almond

10x10 / 3.9" x 3.9"  68



**-A2004.A**

Dec. soffio mix almond

10x10  12



**-A2000.G**

Form. maiolica mix almond

10x10  12



**-A2004.C**

Dec. fiorito mix almond

10x10  12



**-A2004.B**

List. soffio almond

5x20  24



**-A2000.H**

List. maiolica almond

5x20  12



**-A2004.D**

List. fiorito mix almond

5x10  12



ALMOND



**-A2004.I**

Dec. uliveto mix almond

10x10  12



**-A2001.M**

Form. fructis mix bianco/alm/beige

10x10  12



**-A2001.N**

List. fructis bianco/alm/beige

3,5x20  12

PEZZI SPECIALI • SPECIAL TRIMS  
ÉLÉMENTS SPÉCIAUX • SPEZIALTEILE



**-A2004.17**

Double bullnose almond

10x10  18



**-A2004.16**

Bullnose almond

10x10  18



**-A2004.26**

Torello almond

5x20  12



**-A2004.28**

Bombato almond

2x20  12



**-A2004.27**

Ang. tor. almond

5x3  12



**-A2004.29**

Ang. bombato almond

2x2  12



MONOCOTTURA DA RIVESTIMENTO • SINGLE-FIRED WALL TILES  
MONOCUISSON POUR REVÊTEMENT • EINBRAND-WANDFLIESEN



**-A2017.0**

Petraia rosso

10x10 / 3.9" x 3.9"  68



**-A2017.A**

Dec. soffio mix rosso

10x10  12



**-A2000.G**

Form. maiolica mix almond

10x10  12



**-A2017.C**

Dec. fiorito mix rosso

10x10  12



**-A2017.B**

List. soffio rosso

5x20  24



**-A2000.H**

List. maiolica almond

5x20  12



**-A2017.D**

List. fiorito mix rosso

5x10  12



ROSSO



**-A2017.I**

Dec. uliveto mix rosso

10x10  12

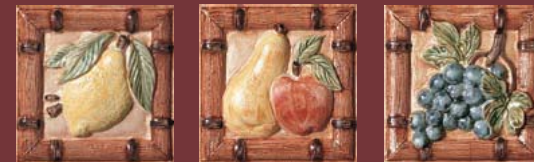

**-A2005.M**

Form. fructis mix ocra/cotto/rosso

10x10  12



**-A2005.N**

List. fructis ocra/cotto/rosso

3,5x20  12

PEZZI SPECIALI • SPECIAL TRIMS  
ÉLÉMENTS SPÉCIAUX • SPEZIALTEILE



**-A2017.17**

Double bullnose rosso

10x10  18



**-A2017.16**

Bullnose rosso

10x10  18



**-A2017.26**

Torello rosso

5x20  12



**-A2017.28**

Bombato rosso

2x20  12



**-A2017.27**

Ang. tor. rosso

5x3  12



**-A2017.29**

Ang. bombato rosso

2x2  12



ROSSO



PETRAIA ROSSO/BIANCO  
FORM. FRUCTIS MIX OCRA/COTTO/ROSSO  
LIST. FRUCTIS OCRA/COTTO/ROSSO  
TAVELLA ROSSA 12,5x25









MONOCOTTURA DA RIVESTIMENTO • SINGLE-FIRED WALL TILES  
MONOCUISSON POUR REVÊTEMENT • EINBRAND-WANDFLIESEN



**-A2008.0**

Petraia verde

10x10 / 3.9" x 3.9"  68



**-A2008.A**

Dec. soffio mix verde

10x10  12



**-A2001.G**

Form. maiolica mix bianco

10x10  12



**-A2008.C**

Dec. fiorito mix verde

10x10  12



**-A2008.B**

List. soffio verde

5x20  24

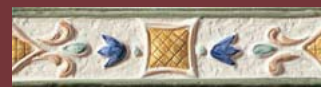

**-A2001.H**

List. maiolica bianco

5x20  12



**-A2008.D**

List. fiorito mix verde

5x10  12



VERDE



**-A2008.I**

Dec. uliveto mix verde

10x10  12



**-A2008.M**

Form. fructis mix verde/nero

10x10  12



**-A2008.N**

List. fructis verde/nero

3,5x20  12

PEZZI SPECIALI • SPECIAL TRIMS  
ÉLÉMENTS SPÉCIAUX • SPEZIALTEILE



**-A2008.17**

Double bullnose verde

10x10  18



**-A2008.16**

Bullnose verde

10x10  18



**-A2008.26**

Torello verde

5x20  12



**-A2008.27**

Ang. tor. verde

5x3  12



**-A2008.28**

Bombato verde

2x20  12



**-A2008.29**

Ang. bombato verde

2x2  12



MONOCOTTURA DA RIVESTIMENTO • SINGLE-FIRED WALL TILES  
MONOCUISSON POUR REVÊTEMENT • EINBRAND-WANDFLIESEN



**-A2001.0**

Petraia bianco

10x10 / 3.9" x 3.9"  68



**-A2001.A**

Dec. soffio mix bianco

10x10  12



**-A2001.G**

Form. maiolica mix bianco

10x10  12



**-A2001.C**

Dec. fiorito mix bianco

10x10  12



**-A2001.H**

List. maiolica bianco

5x20  12



**-A2001.D**

List. fiorito mix bianco

5x10  12



BIANCO



**-A2001.I**

Dec. uliveto mix bianco

10x10  12



**-A2001.M**

Form. fructis mix bianco/alm./beige

10x10  12



**-A2001.N**

List. fructis bianco/alm./beige

3,5x20  12

PEZZI SPECIALI • SPECIAL TRIMS  
ÉLÉMENTS SPÉCIAUX • SPEZIALTEILE



**-A2001.17**

Double bullnose bianco

10x10  18



**-A2001.16**

Bullnose bianco

10x10  18



**-A2001.26**

Torello bianco

5x20  12



**-A2001.27**

Ang. tor. bianco

5x3  12



**-A2001.28**

Bombato bianco

2x20  12



**-A2001.29**

Ang. bombato bianco

2x2  12



PETRAIA BEIGE  
DEC. FIORITO MIX BEIGE  
LIST. FIORITO MIX BEIGE  
MOS. QUADRETTI BEIGE 33,3x33,3

MONOCOTTURA DA RIVESTIMENTO • SINGLE-FIRED WALL TILES  
MONOCUISSON POUR REVÊTEMENT • EINBRAND-WANDFLIESEN



**-A2000.0**

Petraia beige

10x10 / 3.9" x 3.9"  68



**-A2000.A**

Dec. soffio mix beige

10x10  12



**-A2000.G**

Form. maiolica mix almond

10x10  12



**-A2000.C**

Dec. fiorito mix beige

10x10  12



**-A2000.B**

List. soffio beige

5x20  24



**-A2000.H**

List. maiolica almond

5x20  12



**-A2000.D**

List. fiorito mix beige

5x10  12



BEIGE



**-A2000.I**

Dec. uliveto mix beige

10x10  12



**-A2001.M**

Form. fructis mix bianco/alm./beige

10x10  12



**-A2001.N**

List. fructis bianco/alm./beige

3,5x20  12

PEZZI SPECIALI • SPECIAL TRIMS  
ÉLÉMENTS SPÉCIAUX • SPEZIALTEILE



**-A2000.17**

Double bullnose beige

10x10  18



**-A2000.16**

Bullose beige

10x10  18



**-A2000.26**

Torello beige

5x20  12



**-A2000.28**

Bombato beige

2x20  12



**-A2000.27**

Ang. tor. beige

5x3  12



**-A2000.29**

Ang. bombato beige

2x2  12



PETRAIA NERO  
DEC. SOFFIO MIX NERO  
LIST. SOFFIO NERO  
PETRAIA NERO 33,3x33,3

MONOCOTTURA DA RIVESTIMENTO • SINGLE-FIRED WALL TILES  
MONOCUISSON POUR REVÊTEMENT • EINBRAND-WANDFLIESEN



**-A2006.0**

Petraia nero

10x10 / 3.9" x 3.9"  68



**-A2006.A**

Dec. soffio mix nero

10x10  12



**-A2001.G**

Form. maiolica mix bianco

10x10  12



**-A2006.C**

Dec. fiorito mix nero

10x10  12



**-A2006.B**

List. soffio nero

5x20  24



**-A2001.H**

List. maiolica bianco

5x20  12



**-A2006.D**

List. fiorito mix nero

5x10  12



NERO



**-A2006.I**

Dec. uliveto mix nero

10x10  12



**-A2008.M**

Form. fructis mix verde/nero

10x10  12



**-A2008.N**

List. fructis verde/nero

3,5x20  12

PEZZI SPECIALI • SPECIAL TRIMS  
ÉLÉMENTS SPÉCIAUX • SPEZIALTEILE



**-A2006.17**

Double bullnose nero

10x10  18



**-A2006.16**

Bullnose nero

10x10  18



**-A2006.26**

Torello nero

5x20  12



**-A2006.27**

Ang. tor. nero

5x3  12



**-A2006.28**

Bombato nero

2x20  12



**-A2006.29**

Ang. bombato nero

2x2  12

# PEZZI SPECIALI

PER IL RIVESTIMENTO DI STRUTTURE IN MURATURA

SPECIAL TRIMS FOR MASONRY WORK

ÉLÉMENTS SPÉCIAUX POUR LE REVÊTEMENT DE STRUCTURES DE MAÇONNERIE

SPEZIALTEILE FÜR DIE WANDVERKLEIDUNG VON MAUERSTRUKTUREN



SCHEMA DI POSA OTTIMALE • OPTIMAL LAYING PATTERN • SCHÉMA POUR UNE POSE IDÉALE • OPTIMALES VERLEGESCHEMA

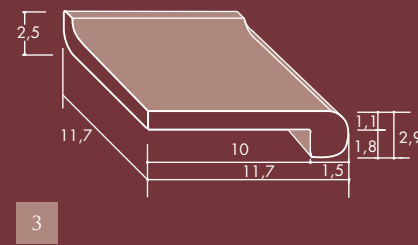
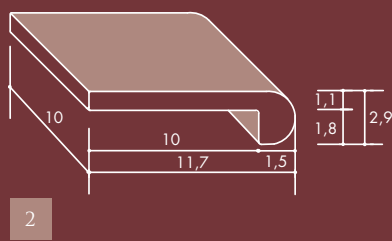
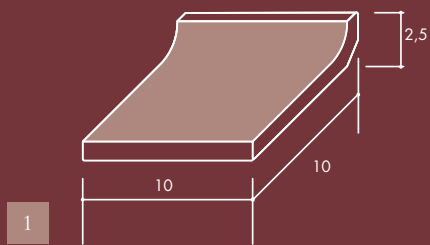



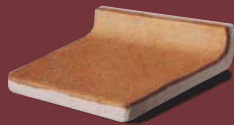

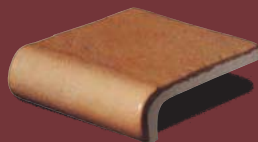

1  
Battistraccio  
10x10  12

- A2001.22 bianco
- A2004.22 almond
- A2000.22 beige
- A2005.22 ocra
- A2007.22 cotto
- A2017.22 rosso
- A2008.22 verde
- A2006.22 nero



2  
Piano lavoro  
10x10  12

- A2001.18 bianco
- A2004.18 almond
- A2000.18 beige
- A2005.18 ocra
- A2007.18 cotto
- A2017.18 rosso
- A2008.18 verde
- A2006.18 nero



FUGA CONSIGLIATA 3 MM  
SUGGESTED JOINT 3 MM

ARTICOLI REALIZZATI A MANO  
HAND-MADE ITEMS



3  
Ang. dx battistraccio  
10x10  3

- A2001.25 bianco
- A2004.25 almond
- A2000.25 beige
- A2005.25 ocra
- A2007.25 cotto
- A2017.25 rosso
- A2008.25 verde
- A2006.25 nero



4  
Spigolo battistraccio  
10x10  4

- A2001.23 bianco
- A2004.23 almond
- A2000.23 beige
- A2005.23 ocra
- A2007.23 cotto
- A2017.23 rosso
- A2008.23 verde
- A2006.23 nero

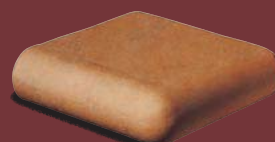

5  
Spigolo  
10x10  8

- A2001.19 bianco
- A2004.19 almond
- A2000.19 beige
- A2005.19 ocra
- A2007.19 cotto
- A2017.19 rosso
- A2008.19 verde
- A2006.19 nero

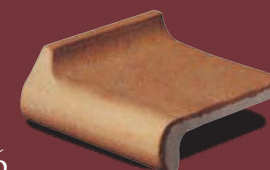

6  
Ang. sx battistraccio  
10x10  3

- A2001.24 bianco
- A2004.24 almond
- A2000.24 beige
- A2005.24 ocra
- A2007.24 cotto
- A2017.24 rosso
- A2008.24 verde
- A2006.24 nero

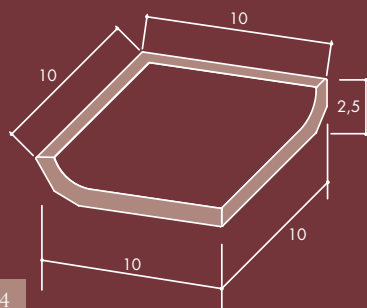

4

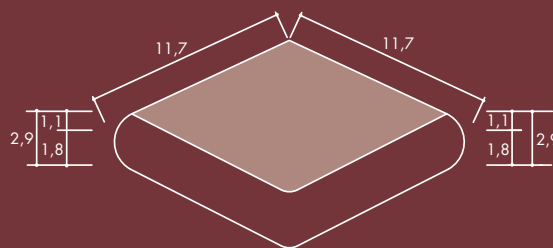

5

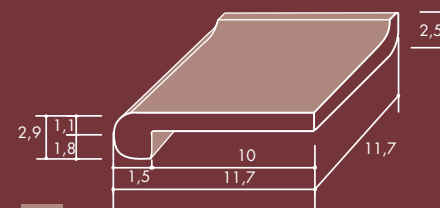

6

# PEZZI SPECIALI

PER IL RIVESTIMENTO DI STRUTTURE IN MURATURA

SPECIAL TRIMS FOR MASONRY WORK

ÉLÉMENTS SPÉCIAUX POUR LE REVÊTEMENT DE STRUCTURES DE MAÇONNERIE

SPEZIALTEILE FÜR DIE WANDVERKLEIDUNG VON MAUERSTRUKTUREN



SCHEMA DI POSA ALTERNATIVO • ALTERNATIVE LAYING PATTERN  
SCHÉMA POUR UNE POSE ALTERNATIVE • ALTERNATIVES VERLEGESCHEMA

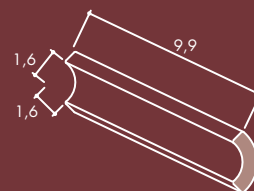

1

2



1  
Sguscia interna  
3x10  12

- A2001.13 bianco
- A2004.13 almond
- A2000.13 beige
- A2005.13 ocra
- A2007.13 cotto
- A2017.13 rosso
- A2008.13 verde
- A2006.13 nero



2  
Ang. sguscia interna  
3x3  12

- A2001.14 bianco
- A2004.14 almond
- A2000.14 beige
- A2005.14 ocra
- A2007.14 cotto
- A2017.14 rosso
- A2008.14 verde
- A2006.14 nero



FUGA CONSIGLIATA 3 MM  
SUGGESTED JOINT 3 MM

ARTICOLI REALIZZATI A MANO  
HAND-MADE ITEMS



3  
Quarter Round  
3x10  12

- A2001.11 bianco
- A2004.11 almond
- A2000.11 beige
- A2005.11 ocra
- A2007.11 cotto
- A2017.11 rosso
- A2008.11 verde
- A2006.11 nero



4  
Ang. Quarter Round  
3x3  12

- A2001.12 bianco
- A2004.12 almond
- A2000.12 beige
- A2005.12 ocra
- A2007.12 cotto
- A2017.12 rosso
- A2008.12 verde
- A2006.12 nero



5  
V-cap  
5x10  12

- A2001.4 bianco
- A2004.4 almond
- A2000.4 beige
- A2005.4 ocra
- A2007.4 cotto
- A2017.4 rosso
- A2008.4 verde
- A2006.4 nero



6  
Ang. v-cap  
10x10  12

- A2001.5 bianco
- A2004.5 almond
- A2000.5 beige
- A2005.5 ocra
- A2007.5 cotto
- A2017.5 rosso
- A2008.5 verde
- A2006.5 nero

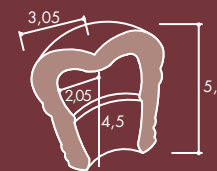
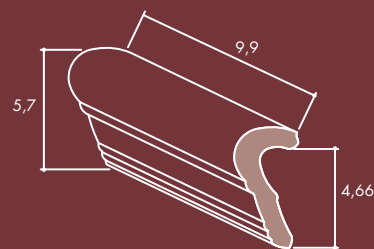
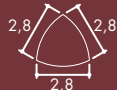
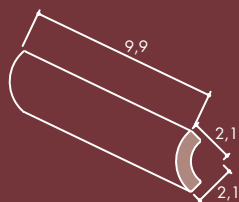

3

4

5

6



P E T R A I A

Nella produzione di prodotti in gres porcellanato esistono dei classici, prodotti cioè che, non si sa per quali misteriose alchimie, raggiungono e aumentano nel tempo tutto il loro valore. Petraia è uno di questi, un obbligato punto di riferimento per tutto ciò che è stato prima e per tutto ciò che verrà dopo. La ragione di ciò non rappresenta alcun mistero; semplicemente l'impegno, la passione, la possibilità di lavorare in piena intesa tra team tecnici e creativi con il fine comune di realizzare un prodotto resistente nella materia e nelle emozioni che procura.

Among the myriad porcelain stoneware products there are some classics which for some unfathomable reason simply go on getting better. Petraia is one of these, a milestone arrived at and always referred back to. And the reason why this is so lies simply in the effort we put into it: the passionate teamwork between technicians and artists who aim at making a tough product that will hang in there through thick and thin. One that will continue to arouse our emotions.

La production en grès cérame offre les classiques, produits dont la valeur, par quelque mystérieuse alchimie, augmente au fil du temps.

Petraia est un de ces classiques, point de référence obligé pour la production passée et la production à venir. La raison en est tout simplement le travail, la passion et l'étroite collaboration entre techniciens et créatifs, œuvrant dans un but commun, celui de réaliser un produit résistant au temps et suscitant des émotions durables.

Unter den Feinsteinzeugprodukten gibt es Klassiker, d.h. Produkte, von denen man nicht weiß, aus welchen mysteriösen Gründen sie im Laufe der Zeit ihren vollen Wert erreichen und ihn noch weiter erhöhen. Petraia ist einer dieser Klassiker, ein unumgehbarer Referenzpunkt für all das was einmal war und was noch sein wird. Der Grund dafür liegt einzig und allein am Eifer, an der Begeisterung und an der Möglichkeit einer Arbeit in vollem Einverständnis zwischen dem technischen und kreativen Team, mit dem gemeinsamen Ziel der Realisierung eines Produktes, dessen Material und bereiteten Emotionen der Zeit standhalten.







O C R A  
A L M O N D  
P E T R A I A

PETRAIA ALMOND 50x50 - 33,3x33,3 - 25x25 - 16,65x33,3 - 16,65x16,65  
PETRAIA OCRA 33,3x33,3







**R O S S O**  
P E T R A I A

PETRAIA ROSSO 16,65x33,3





C O T T O  
B E I G E  
P E T R A I A

PETRAIA BEIGE 25x25 - 12,5x25 - 12,5x12,5  
PETRAIA COTTO 25x25 - 12,5x12,5





**B E I G E**  
**N E R O**  
P E T R A I A

PETRAIA BEIGE 50x50 - 33,3x33,3 - 12,5x12,5  
PETRAIA NERO 12,5x12,5 - 25x25





A L M O N D  
V E R D E  
P E T R A I A

PETRAIA VERDE 25x25 - 12,5x25 - 12,5x12,5  
PETRAIA ALMOND 25x25 - 12,5x12,5

# A L M O N D



**-A6104.0**

Petraia almond PEI IV  
50x50 / 20"x20"  6



**-A8524.0**

Petraia almond PEI IV  
33,3x33,3 / 13"x13"  11



**-A8524.7P**

Petraia tavella almond PEI IV  
16,65x33,3 / 6.5"x13"  22  
**TAVELLA DA PRESSA**



**-A8524.8P**

Petraia tozzetto almond PEI IV  
16,65x16,65 / 6.5"x6.5"  44



**-A5004.0**

Petraia almond PEI IV  
25x25 / 10"x10"  18



**-A5004.7P**

Petraia tavella almond PEI IV  
12,5x25 / 5"x10"  36  
**TAVELLA DA PRESSA**



**-A5004.8P**

Petraia tozzetto almond PEI IV  
12,5x12,5 / 5"x5"  72



**-A5004.A**

Parquet  
25x35  10



**-A5004.H**

Freccia Triangoli  
12,5x25  8



**-A5004.M**

Raccordo parquet  
4x36  10



**-A5004.G**

Freccia rettangoli  
12,5x25  8



**-A5004.B**

Tozzetto araldico (2 soggetti)  
12,5x12,5  12



50 x 50 | 33,3 x 33,3 | 16,65 x 33,3 | 25 x 25 | 16,65 x 16,65 | 12,5 x 25 | 12,5 x 12,5  
 20" x 20" | 13" x 13" | 6.5" x 13" | 10" x 10" | 6.5" x 6.5" | 5" x 10" | 5" x 5"

GRES PORCELLANATO SMALTATO  
 GLAZED PORCELAIN TILES





**-A8524.D**  
 Tozzetto Firenze A  
 16,65x16,65  12



**-A8524.E**  
 Tozzetto Firenze B  
 16,65x16,65  12



**-A8524.F**  
 Tozzetto Firenze C  
 16,65x16,65  12

**-A8524.C**  
 Tozzetto Firenze mix (3 sogg.)  
 16,65x16,65  12

MOSAICO • MOSAIC • MOSAÏQUE • MOSAIK



**-A8524.X**  
 Mosaico brick mix almond ( 3 sogg.)  
 33,3x33,3  6



**-A8524.U**  
 Mosaico quadretti almond  
 33,3x33,3  5



**-A8524.UM**  
 Mos. quadretti almond/verde  
 33,3x33,3  5

PEZZI SPECIALI • SPECIAL TRIMS  
 ÉLÉMENTS SPÉCIAUX • SPEZIALTEILE



**-A5004.11**  
 Quarter round  
 2,5x12,5  20



**-A5004.12**  
 Sgriscia  
 2,5x1  20



**-A5004.4**  
 V-cap lineare  
 5x12,5  12



**-A5004.5**  
 C-cap  
 5x5  20



**-A5004.T**  
 Torello gradino  
 5,5x39  6

# R O S S O



**-A6117.0**

Petraia rosso PEI IV  
50x50 / 20"x20"  6



**-A8537.0**

Petraia rosso PEI IV  
33,3x33,3 / 13"x13"  11



**-A8537.7P**

Petraia Tavella rossa PEI IV  
16,65x33,3 / 6.5"x13"  22  
**TAVELLA DA PRESSA**



**-A8537.8P**

Petraia Tozzetto rosso PEI IV  
16,65x16,65 / 6.5"x6.5"  44



**-A5017.0**

Petraia rosso PEI IV  
25x25 / 10"x10"  18



**-A5017.7P**

Petraia Tavella rosso PEI IV  
12,5x25 / 5"x10"  36  
**TAVELLA DA PRESSA**



**-A5017.8P**

Petraia Tozzetto rosso PEI IV  
12,5x12,5 / 5"x5"  72



**-A5017.A**

Parquet  
25x35  10



**-A5017.H**

Freccia Triangoli  
12,5x25  8



**-A5017.M**

Raccordo parquet  
4x36  10



**-A5017.G**

Freccia rettangoli  
12,5x25  8



**-A5017.B**

Tozzetto araldico (2 soggetti)  
12,5x12,5  12

50 x 50 | 33,3 x 33,3 | 16,65 x 33,3 | 25 x 25 | 16,65 x 16,65 | 12,5 x 25 | 12,5 x 12,5  
 20" x 20" | 13" x 13" | 6.5" x 13" | 10" x 10" | 6.5" x 6.5" | 5" x 10" | 5" x 5"

GRES PORCELLANATO SMALTATO  
 GLAZED PORCELAIN TILES



**-A8537.D**

Tozzetto Firenze A

16,65x16,65  12



**-A8537.E**

Tozzetto Firenze B

16,65x16,65  12



**-A8537.F**

Tozzetto Firenze C

16,65x16,65  12

**-A8537.C**

Tozzetto Firenze mix (3 sogg.)

16,65x16,65  12

MOSAICO • MOSAIC • MOSAÏQUE • MOSAIK



**-A8537.X**

Mosaico brick mix rosso (3 sogg.)

33,3x33,3  6



**-A8537.U**

Mosaico quadretti rosso

33,3x33,3  5



**-A8525.UM**

Mos. quadretti ocre/cotto/rosso

33,3x33,3  5

PEZZI SPECIALI • SPECIAL TRIMS  
 ÉLÉMENTS SPÉCIAUX • SPEZIALTEILE



**-A5017.11**

Quarter round

2,5x12,5  20



**-A5017.12**

Sguscia

2,5x1  20



**-A5017.4**

V-cap lineare

5x12,5  12



**-A5017.5**

C-cap

5x5  20



**-A5017.T**

Torello gradino

5,5x39  6

# B E I G E



**-A6100.0**

Petraia beige

PEI IV

50x50 / 20"x20"

📦 6



**-A8520.0**

Petraia beige

PEI IV

33,3x33,3 / 13"x13"

📦 11



**-A8520.7P**

Petraia tavella beige

PEI IV

16,65x33,3 / 6.5"x13"

📦 22

TAVELLA DA PRESSA



**-A8520.8P**

Petraia tozzetto beige

PEI IV

16,65x16,65 / 6.5"x6.5"

📦 44



**-A5000.0**

Petraia beige

PEI IV

25x25 / 10"x10"

📦 18



**-A5000.7P**

Petraia tavella beige

PEI IV

12,5x25 / 5"x10"

📦 36

TAVELLA DA PRESSA



**-A5000.8P**

Petraia tozzetto beige

PEI IV

12,5x12,5 / 5"x5"

📦 72



**-A5000.A**

Parquet

25x35

📦 10



**-A5000.H**

Freccia Triangoli

12,5x25

📦 8



**-A5000.M**

Raccordo parquet

4x36

📦 10



**-A5000.G**

Freccia rettangoli

12,5x25

📦 8



**-A5000.B**

Tozzetto araldico (2 soggetti)

12,5x12,5

📦 12

50 x 50 | 33,3 x 33,3 | 16,65 x 33,3 | 25 x 25 | 16,65 x 16,65 | 12,5 x 25 | 12,5 x 12,5  
 20" x 20" | 13" x 13" | 6.5" x 13" | 10" x 10" | 6.5" x 6.5" | 5" x 10" | 5" x 5"

GRES PORCELLANATO SMALTATO  
 GLAZED PORCELAIN TILES



**-A8520.D**

Tozzetto Firenze A

16,65x16,65  12



**-A8520.E**

Tozzetto Firenze B

16,65x16,65  12



**-A8520.F**

Tozzetto Firenze C

16,65x16,65  12

**-A8520.C**

Tozzetto Firenze mix (3 sogg.)

16,65x16,65  12

MOSAICO • MOSAIC • MOSAÏQUE • MOSAIK



**-A8520.X**

Mosaico brick mix beige (3 sogg.)

33,3x33,3  6



**-A8520.U**

Mosaico quadretti beige

33,3x33,3  5



**-A8520.UM**

Mos. quadretti beige/nero

33,3x33,3  5

PEZZI SPECIALI • SPECIAL TRIMS  
 ÉLÉMENTS SPÉCIAUX • SPEZIALTEILE



**-A5000.11**

Quarter round

2,5x12,5  20



**-A5000.12**

Sguscia

2,5x1  20



**-A5000.4**

V-cap lineare

5x12,5  12



**-A5000.5**

C-cap

5x5  20



**-A5000.T**

Torello gradino

5,5x39  6

# C O T T O



**-A6107.0**

|                 |        |
|-----------------|--------|
| Petraia cotto   | PEI IV |
| 50x50 / 20"x20" | 6      |



**-A8527.0**

|                     |        |
|---------------------|--------|
| Petraia cotto       | PEI IV |
| 33,3x33,3 / 13"x13" | 11     |



**-A8527.7P**

|                       |        |
|-----------------------|--------|
| Petraia tavella cotto | PEI IV |
| 16,65x33,3 / 6.5"x13" | 22     |

**TAVELLA DA PRESSA**



**-A8527.8P**

|                         |        |
|-------------------------|--------|
| Petraia tozzetto cotto  | PEI IV |
| 16,65x16,65 / 6.5"x6.5" | 44     |



**-A5007.0**

|                 |        |
|-----------------|--------|
| Petraia cotto   | PEI IV |
| 25x25 / 10"x10" | 18     |



**-A5007.7P**

|                       |        |
|-----------------------|--------|
| Petraia tavella cotto | PEI IV |
| 12,5x25 / 5"x10"      | 36     |

**TAVELLA DA PRESSA**



**-A5007.8P**

|                        |        |
|------------------------|--------|
| Petraia tozzetto cotto | PEI IV |
| 12,5x12,5 / 5"x5"      | 72     |



**-A5007.A**

|         |    |
|---------|----|
| Parquet |    |
| 25x35   | 10 |



**-A5017.H**

|                   |   |
|-------------------|---|
| Freccia Triangoli |   |
| 12,5x25           | 8 |



**-A5007.M**

|                  |    |
|------------------|----|
| Raccordo parquet |    |
| 4x36             | 10 |



**-A5007.G**

|                    |   |
|--------------------|---|
| Freccia rettangoli |   |
| 12,5x25            | 8 |



**-A5017.B**

|                                |    |
|--------------------------------|----|
| Tozzetto araldico (2 soggetti) |    |
| 12,5x12,5                      | 12 |

50 x 50 | 33,3 x 33,3 | 16,65 x 33,3 | 25 x 25 | 16,65 x 16,65 | 12,5 x 25 | 12,5 x 12,5  
 20" x 20" | 13" x 13" | 6.5" x 13" | 10" x 10" | 6.5" x 6.5" | 5" x 10" | 5" x 5"

GRES PORCELLANATO SMALTATO  
 GLAZED PORCELAIN TILES



**-A8527.D**

Tozzetto Firenze A

16,65x16,65  12



**-A8527.E**

Tozzetto Firenze B

16,65x16,65  12



**-A8527.F**

Tozzetto Firenze C

16,65x16,65  12

**-A8527.C**

Tozzetto Firenze mix (3 sogg.)

16,65x16,65  12

MOSAICO • MOSAIC • MOSAÏQUE • MOSAIK



**-A8527.X**

Mosaico brick mix cotto (3 sogg.)

33,3x33,3  6



**-A8527.U**

Mosaico quadretti cotto

33,3x33,3  5



**-A8525.UM**

Mos. quadretti ocre/cotto/rosso

33,3x33,3  5

PEZZI SPECIALI • SPECIAL TRIMS  
 ÉLÉMENTS SPÉCIAUX • SPEZIALTEILE



**-A5007.11**

Quarter round

2,5x12,5  20



**-A5007.12**

Sguscia

2,5x1  20



**-A5007.4**

V-cap lineare

5x12,5  12



**-A5007.5**

C-cap

5x5  20



**-A5007.T**

Torello gradino

5,5x39  6

# N E R O



**-A6106.0**

Petraia nero PEI IV  
50x50 / 20"x20"  6



**-A8526.0**

Petraia nero PEI IV  
33,3x33,3 / 13"x13"  11



**-A8526.7P**

Petraia tavella nero PEI IV  
16,65x33,3 / 6.5"x13"  22  
**TAVELLA DA PRESSA**



**-A8526.8P**

Petraia tozzetto nero PEI IV  
16,65x16,65 / 6.5"x6.5"  44



**-A5006.0**

Petraia nero PEI IV  
25x25 / 10"x10"  18



**-A5006.7P**

Petraia tavella nero PEI IV  
12,5x25 / 5"x10"  36  
**TAVELLA DA PRESSA**



**-A5006.8P**

Petraia tozzetto nero PEI IV  
12,5x12,5 / 5"x5"  72



**-A5006.A**

Parquet  
25x35  10



**-A5006.H**

Freccia Triangoli  
12,5x25  8



**-A5006.M**

Raccordo parquet  
4x36  10



**-A5006.G**

Freccia rettangoli  
12,5x25  8



**-A5006.B**

Tozzetto araldico (2 soggetti)  
12,5x12,5  12



50 x 50 | 33,3 x 33,3 | 16,65 x 33,3 | 25 x 25 | 16,65 x 16,65 | 12,5 x 25 | 12,5 x 12,5  
 20" x 20" | 13" x 13" | 6.5" x 13" | 10" x 10" | 6.5" x 6.5" | 5" x 10" | 5" x 5"

GRES PORCELLANATO SMALTATO  
 GLAZED PORCELAIN TILES



**-A8526.D**

Tozzetto Firenze A

16,65x16,65  12



**-A8526.E**

Tozzetto Firenze B

16,65x16,65  12



**-A8526.F**

Tozzetto Firenze C

16,65x16,65  12

**-A8526.C**

Tozzetto Firenze mix (3 sogg.)

16,65x16,65  12

MOSAICO • MOSAIC • MOSAÏQUE • MOSAIK



**-A8526.X**

Mosaico brick mix nero (3 sogg.)

33,3x33,3  6



**-A8526.U**

Mosaico quadretti nero

33,3x33,3  5



**-A8520.UM**

Mos. quadretti beige/nero

33,3x33,3  5

PEZZI SPECIALI • SPECIAL TRIMS  
 ÉLÉMENTS SPÉCIAUX • SPEZIALTEILE



**-A5006.11**

Quarter round

2,5x12,5  20



**-A5006.12**

Sguscia

2,5x1  20



**-A5006.4**

V-cap lineare

5x12,5  12



**-A5006.5**

C-cap

5x5  20



**-A5006.T**

Torello gradino

5,5x39  6

# O C R A



**-A6105.0**

Petraia ocra PEI IV  
50x50 / 20"x20" 6



**-A8525.0**

Petraia ocra PEI IV  
33,3x33,3 / 13"x13" 11



**-A8525.7P**

Petraia Tavella ocra PEI IV  
16,65x33,3 / 6.5"x13" 22  
**TAVELLA DA PRESSA**



**-A8525.8P**

Petraia Tozzetto ocra PEI IV  
16,65x16,65 / 6.5"x6.5" 44



**-A5005.0**

Petraia ocra PEI IV  
25x25 / 10"x10" 18



**-A5005.7P**

Petraia Tavella ocra PEI IV  
12,5x25 / 5"x10" 36  
**TAVELLA DA PRESSA**



**-A5005.8P**

Petraia tozzetto ocra PEI IV  
12,5x12,5 / 5"x5" 72



**-A5005.A**

Parquet  
25x35 10



**-A5017.H**

Freccia Triangoli  
12,5x25 8



**-A5005.M**

Raccordo parquet  
4x36 10



**-A5005.G**

Freccia rettangoli  
12,5x25 8



**-A5005.B**

Tozzetto araldico (2 soggetti)  
12,5x12,5 12

50 x 50 | 33,3 x 33,3 | 16,65 x 33,3 | 25 x 25 | 16,65 x 16,65 | 12,5 x 25 | 12,5 x 12,5  
 20" x 20" | 13" x 13" | 6.5" x 13" | 10" x 10" | 6.5" x 6.5" | 5" x 10" | 5" x 5"

GRES PORCELLANATO SMALTATO  
 GLAZED PORCELAIN TILES





**-A8525.D**  
 Tozzetto Firenze A  
 16,65x16,65  12



**-A8525.E**  
 Tozzetto Firenze B  
 16,65x16,65  12



**-A8525.F**  
 Tozzetto Firenze C  
 16,65x16,65  12

**-A8525.C**  
 Tozzetto Firenze mix (3 sogg.)  
 16,65x16,65  12

MOSAICO • MOSAIC • MOSAÏQUE • MOSAIK



**-A8525.X**  
 Mosaico brick mix ocra (3 sogg.)  
 33,3x33,3  6



**-A8525.U**  
 Mosaico quadretti ocra  
 33,3x33,3  5



**-A8525.UM**  
 Mos. quadretti ocra/cotto/rosso  
 33,3x33,3  5

PEZZI SPECIALI • SPECIAL TRIMS  
 ÉLÉMENTS SPÉCIAUX • SPEZIALTEILE



**-A5005.11**  
 Quarter round  
 2,5x12,5  20



**-A5005.12**  
 Sguscia  
 2,5x1  20



**-A5005.4**  
 V-cap lineare  
 5x12,5  12



**-A5005.5**  
 C-cap  
 5x5  20



**-A5005.T**  
 Torello gradino  
 5,5x39  6

# V E R D E



**-A6108.0**

Petraia verde

PEI IV

50x50 / 20"x20"

📦 6



**-A8528.0**

Petraia verde

PEI IV

33,3x33,3 / 13"x13"

📦 11



**-A8528.7P**

Petraia tavella verde

PEI IV

16,65x33,3 / 6.5"x13"

📦 22

TAVELLA DA PRESSA



**-A8528.8P**

Petraia tozzetto verde

PEI IV

16,65x16,65 / 6.5"x6.5"

📦 44



**-A5008.0**

Petraia verde

PEI IV

25x25 / 10"x10"

📦 18



**-A5008.7P**

Petraia tavella verde

PEI IV

12,5x25 / 5"x10"

📦 36

TAVELLA DA PRESSA



**-A5008.8P**

Petraia tozzetto verde

PEI IV

12,5x12,5 / 5"x5"

📦 72



**-A5008.A**

Parquet

25x35

📦 10



**-A5008.H**

Freccia Triangoli

12,5x25

📦 8



**-A5008.M**

Raccordo parquet

4x36

📦 10



**-A5008.G**

Freccia rettangoli

12,5x25

📦 8



**-A5008.B**

Tozzetto araldico (2 soggetti)

12,5x12,5

📦 12

50 x 50 | 33,3 x 33,3 | 16,65 x 33,3 | 25 x 25 | 16,65 x 16,65 | 12,5 x 25 | 12,5 x 12,5  
 20" x 20" | 13" x 13" | 6.5" x 13" | 10" x 10" | 6.5" x 6.5" | 5" x 10" | 5" x 5"

GRES PORCELLANATO SMALTATO  
 GLAZED PORCELAIN TILES



**-A8528.D**

Tozzetto Firenze A

16,65x16,65  12



**-A8528.E**

Tozzetto Firenze B

16,65x16,65  12



**-A8528.F**

Tozzetto Firenze C

16,65x16,65  12

**-A8528.C**

Tozzetto Firenze mix (3 sogg.)

16,65x16,65  12

MOSAICO • MOSAIC • MOSAÏQUE • MOSAIK



**-A8528.X**

Mosaico brick mix verde (3 sogg.)

33,3x33,3  6



**-A8528.U**

Mosaico quadretti verde

33,3x33,3  5



**-A8524.UM**

Mos. quadretti almond/verde

33,3x33,3  5

PEZZI SPECIALI • SPECIAL TRIMS  
 ÉLÉMENTS SPÉCIAUX • SPEZIALTEILE



**-A5008.11**

Quarter round

2,5x12,5  20



**-A5008.12**

Sguscia

2,5x1  20



**-A5008.4**

V-cap lineare

5x12,5  12



**-A5008.5**

C-cap

5x5  20



**-A5008.T**

Torello gradino

5,5x39  6

# Decorations • Patterns • Décors • Dekore

## SCATOLA 4 SOGGETTI MISTI LISTELLI: -A5017.E



**-A5017.V**

Listello decorato

12,5x25

12



**-A5017.S**

Listello decorato

12,5x25

12



**-A5017.Q**

Listello decorato

12,5x25

12



**-A5017.J**

Listello decorato

12,5x25

12

## SCATOLA 4 SOGGETTI MISTI TOZZETTI: -A5017.D



**-A5017.W**

Tozzetto decorato

12,5x12,5

12



**-A5017.X**

Tozzetto decorato

12,5x12,5

12



**-A5017.P**

Tozzetto decorato

12,5x12,5

12



**-A5017.K**

Tozzetto decorato

12,5x12,5

12



**-A5007.F**

Inserto chianti

25x25

12

Decorations matching the Petraia Ochre - Red and Cotto • Patterns which match the Ochre, Red and Cotto Petraia plain tiles  
Décors se mariant aux fonds Petraia Ocre, Rouge et Terre cuite • Dekore, mit Petraia-Grundfliese Ocker, Rot, Cotto kombinierbar

Si consiglia di pulire la superficie senza utilizzare prodotti contenenti sostanze abrasive

54 Do not use products containing abrasive substances to clean the surface

## Consigli di posa

Al fine di valorizzare le caratteristiche estetiche e qualitative di PETRAIA Abk fornisce alcuni consigli utili per una posa corretta del prodotto.

Dopo aver affidato l'esecuzione dei lavori a personale qualificato e prima dell'inizio della posa, controllare la qualità del materiale e la planarità della caldana su cui verranno effettuati.

Durante la stesura dei formati grandi, evitare di far coincidere i vertici di una piastrella con la metà delle

altre a fianco, per ovviare alle imperfezioni di planarità riscontrabili talvolta nei prodotti ceramici.

A tale scopo si consiglia inoltre di mantenere una fuga di 2 mm tra una piastrella e l'altra.

Infine per ottenere un risultato estetico impeccabile, è consigliabile utilizzare sigillanti in tono con il colore della piastrella, oppure di una gradazione leggermente più chiara.

## Advices for laying

In order to enhance the aesthetic and qualitative features of PETRAIA, Abk supplies useful informations on how to lay the product properly.

After hiring skilled workers and before laying, please double-check the quality of both the material and the flatness of the concrete cast.

Do not lay large sizes in a brick pattern, in order to

avoid any possible flatness flaw the ceramic products sometimes might involve.

To this end a 2mm joint is recommended.

However, in order to get the best aesthetic results, please use sealants matching as much as possible the hues of the tiles.

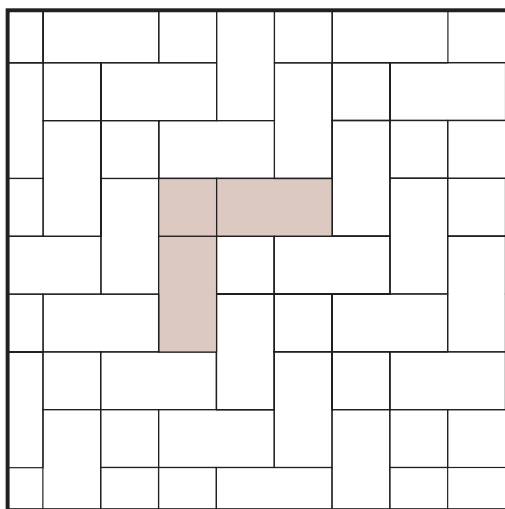

|             | %  |
|-------------|----|
| 16,65x33,3  | 80 |
| 16,65x16,65 | 20 |

## Sigillanti coordinati per fughe

### Coordinated grout sealants

ABK in collaborazione con Hard Koll presenta una gamma di sigillanti speciali in polvere per fughe, coordinati ai colori PETRAIA.

ABK, in cooperation with Hard Koll, introduces a new line of special grout powder adhesives, matching perfectly the colors of the PETRAIA collection.



| Codice sigillante Sealant code            | Abbinamento Matching   |
|---|--|
| <b>SI234B</b> Kromos bahama beige 0 - 8   |  almond |
| <b>SI220B</b> Kromos antracite 0 - 8      |  rosso  |
| <b>SI219B</b> Kromos grigio cemento 0 - 8 |  cotto  |
| <b>SI219B</b> Kromos grigio cemento 0 - 8 |  nero   |
| <b>SI220B</b> Kromos antracite 0 - 8      |  beige  |
| <b>SI234B</b> Kromos bahama beige 0 - 8   |  verde  |
| <b>SI219B</b> Kromos grigio cemento 0 - 8 |  ocra   |
| <b>SI220B</b> Kromos antracite 0 - 8      |  |
| <b>SI219B</b> Kromos grigio cemento 0 - 8 |  |

### KROMOS

Sigillante professionale ad elevata resistenza, a base di leganti idraulici, quarzo, additivi specifici.

Permette di sigillare pavimenti e rivestimenti, per giunti da 0 a 8 mm.

Le caratteristiche di impermeabilità all'acqua battente e

idrorepellenza, garantiscono un'elevata resistenza alle aggressioni chimiche, abrasioni ed efflorescenze. Favorisce inoltre un'elevata capacità di resistenza allo sporco. È calpestabile dopo 3 ore.

### NATURE OF THE PRODUCT

Professional and highly resistant sealant mainly consisting of hydraulic binders, quartz and specific additives.

#### MAIN FEATURES

- Rainproof
- Water-repellent
- Resistant to chemical aggressions
- Highly resistant to filth

- Resistant to abrasions and efflorescences

#### FIELDS OF USE

Wall and floor sealant for 0 - 8 mm gaps.

#### RECOMMENDATIONS

It is able to withstand light foot traffic 3 hours after installation.

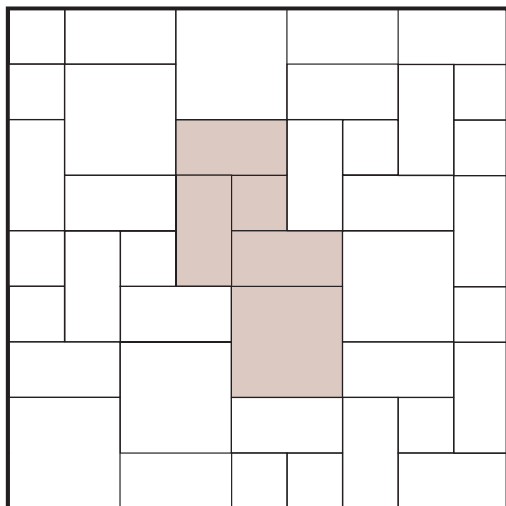

|             | %  |
|-------------|----|
| 33,3x33,3   | 37 |
| 16,65x33,3  | 54 |
| 16,65x16,65 | 9  |

# Pezzi speciali • Special trims Éléments spéciaux • Spezialteile

33,3 x 33,3  
13" x 13"

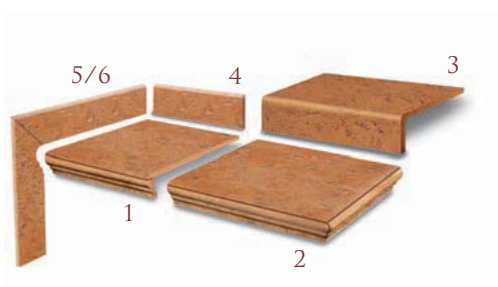

1

Gradino torelo

33,3x33,3

6

**-A8524.4** almond  
**-A8537.4** rosso  
**-A8520.4** beige  
**-A8527.4** cotto  
**-A8526.4** nero  
**-A8525.4** ocra  
**-A8528.4** verde

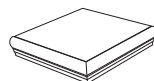

2

Angolare torelo

33,3x33,3

2

**-A8524.5** almond  
**-A8537.5** rosso  
**-A8520.5** beige  
**-A8527.5** cotto  
**-A8526.5** nero  
**-A8525.5** ocra  
**-A8528.5** verde



3

Elemento "L" Monolitico

33,3x16,65x5

8

**-A8524.3** almond  
**-A8537.3** rosso  
**-A8520.3** beige  
**-A8527.3** cotto  
**-A8526.3** nero  
**-A8525.3** ocra  
**-A8528.3** verde



4

Battiscopa

8x33,3

18

**-A8524.6** almond  
**-A8537.6** rosso  
**-A8520.6** beige  
**-A8527.6** cotto  
**-A8526.6** nero  
**-A8525.6** ocra  
**-A8528.6** verde

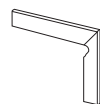

5

Battiscala dx

33,3x33,3

6

**-A8524.Y** almond  
**-A8537.Y** rosso  
**-A8520.Y** beige  
**-A8527.Y** cotto  
**-A8526.Y** nero  
**-A8525.Y** ocra  
**-A8528.Y** verde

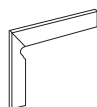

6

Battiscala sx

33,3x33,3

6

**-A8524.Z** almond  
**-A8537.Z** rosso  
**-A8520.Z** beige  
**-A8527.Z** cotto  
**-A8526.Z** nero  
**-A8525.Z** ocra  
**-A8528.Z** verde

33,3 x 33,3  
13" x 13"

MONOLITICO

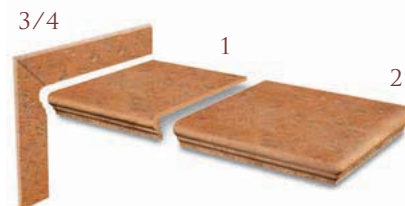

1

Gradino monolitico

30x33,3

6

**-A8537.11** rosso  
**-A8527.11** cotto  
**-A8525.11** ocra

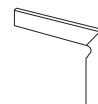

3

Battiscala dx per Monolitico

30x33,3

6

**-A8537.MY** rosso  
**-A8527.MY** cotto  
**-A8525.MY** ocra



25 x 25  
10" x 10"

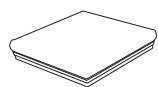
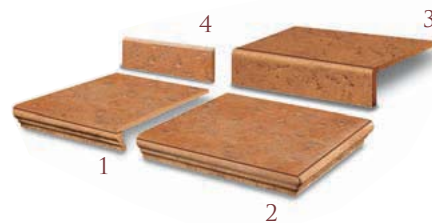

2

Angolare monolitico

33,3x33,3  4

**-A8537.12** rosso

**-A8527.12** cotto

**-A8525.12** ocra

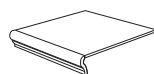

1

Gradino torelo

25x25  6

**-A5004.1** almond

**-A5017.1** rosso

**-A5000.1** beige

**-A5007.1** cotto

**-A5006.1** nero

**-A5005.1** ocra

**-A5008.1** verde

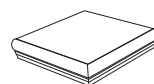

2

Angolare torelo

25x25  2

**-A5004.2** almond

**-A5017.2** rosso

**-A5000.2** beige

**-A5007.2** cotto

**-A5006.2** nero

**-A5005.2** ocra

**-A5008.2** verde

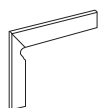

4

Battiscala sx per Monolitico

 6

**-A8537.MZ** rosso

**-A8527.MZ** cotto

**-A8525.MZ** ocra



3

Punto "L"

25x12,5x5  8

**-A5004.3** almond

**-A5017.3** rosso

**-A5000.3** beige

**-A5007.3** cotto

**-A5006.3** nero

**-A5005.3** ocra

**-A5008.3** verde



4

Battiscopa

7,5x25  18

**-A5004.6** almond

**-A5017.6** rosso

**-A5000.6** beige

**-A5007.6** cotto

**-A5006.6** nero

**-A5005.6** ocra

**-A5008.6** verde



# I LOVE GREEN®

ECO-CERAMIC MANUFACTURING

Uomo e ambiente.

Immaginate una mentalità produttiva attenta alle esigenze ambientali ed ai consumi di energia. Immaginate una nuova idea di azienda ceramica che impegna le sue risorse per tutelare il mondo nel quale viviamo.

I love Green di Abk nasce da questo pensiero.

Un modo autentico di coniugare un alto profilo tecnologico e l'amore per il territorio attraverso cinque diversi campi di azione: emissioni in atmosfera, utilizzo delle acque, riciclo dei rifiuti/residui di produzione, consumi di energia, emissioni di anidride carbonica. Un impegno concreto per innalzare i valori aziendali ed orientare tutte le risorse ai fini del risparmio energetico e della sostenibilità ambientale. Nel dettaglio queste le operazioni realizzate:

- attraverso l'uso di sofisticate tecnologie, le emissioni inquinanti in atmosfera sono ridotte al minimo;
- nessuno scarico idrico nell'ambiente, tramite un circuito di acque chiuse che riutilizza completamente i liquidi dedicati al ciclo di produzione;
- i rifiuti/residui di produzione degli smalti e delle materie prime per l'impasto sono reimpiegati interamente nel ciclo produttivo;
- si riducono i consumi di energia, evitando inutili sprechi, attraverso migliori dispositivi di recupero termico degli impianti;
- le emissioni di anidride carbonica vengono abbattute per rientrare largamente nei valori delle norme.

Questo impegno ha prodotto risultati tangibili che, oltre a rispettare la normativa imposta dalle autorità competenti, ci permettono di realizzare performance ambientali migliori rispetto agli standard di riferimento del settore ceramico.

I love Green di Abk. Un impegno concreto che va oltre le idee.

Man and the environment.

Imagine a manufacturing mentality that addresses environmental and energy efficiency issues. Imagine a new concept of a ceramic tile manufacturing concern in which resources are channelled into safeguarding the world in which we live.

I love Green by ABK is the result of this concept.

It combines high technological content with a love of the land by working in five different fields of activity: atmospheric emissions; water consumption; the recycling of waste/process excess; energy consumption and CO<sub>2</sub> emissions. It is about genuine commitment to raising corporate values and channelling all resources into energy efficiency and environmental sustainability, and has led to the following:

- a significant reduction in the emission of air pollutants using sophisticated technologies;
- the prevention of the release of wastewater into the environment thanks to a closed-circuit system that reuses all the liquids involved in the process cycle;
- the reclaiming and re-use of waste/process excess of glazes and raw materials used for tile bodies in the process cycle;
- increased energy efficiency using improved methods to recover heat from plant systems;
- the lowering of CO<sub>2</sub> emissions to well levels within current regulations.

This commitment has yielded tangible results that comply with the regulations set by governing bodies while also enabling us to give greater environmental performance in relation to the reference standard for the ceramic sector.

I love Green by ABK a genuine commitment that transcends mere abstraction.



**ABK Group**  
Industrie Ceramiche s.p.a.  
via S. Lorenzo 24/a  
41034 Finale Emilia Modena - Italy  
Tel. 0535 761311 Fax 0535 761320/92800/761351  
**abk.it**